

BLOCKS- OVERHEAD CRANE



OVERHEAD BRIDGE CRANE BLOCKS

Wide capacity range, made to application, new or replacement

- Working loads from 15 tons to 300 tons
- Design factor 4:1 and up per specification
- All CMAA service classes (also FEM, DIN, ISO)
- Hooks are forged alloy in accord with DIN 15041 or 15402, single or duplex on thrust bearing and crosshead
- Hook lock or motorized hook available
- Fabricated, roll-formed or cast sheaves with roller bearings or bronze bushings
- Optional lubrication through sheave shaft
- Heavy duty sheave guards
- Optional slotted covers over sheaves
- Special configurations, sheave spacings
- Optional insulated hook



*See next page
for
Quote Request
form...*

Miller Lifting Products
 100A Sturbridge Rd.
 Charlton, MA 01507 USA
 T: +1.508.248.3941
 E-mail: sales@millerproducts.net



OVERHEAD CRANE BLOCKS CUSTOM QUOTE REQUEST

Requestor name	Date	Quantity
Company & address		
Phone and E-mail address		

SHEAVES

NUMBER OF SHEAVES: _____ PITCH DIAMETER: _____ OUTSIDE DIAMETER: _____

WIRE ROPE SIZE: _____ NUMBER OF LINE PARTS: _____ EQUALIZER? _____

ROLLER BEARING _____ BRONZE BUSHING _____

BLOCK CAPACITY & DIMENSIONS

DIMENSIONS: A _____ B _____ C _____

WORKING CAPACITY (LOAD LIMIT): _____
 (INDICATE US / METRIC TONS)

DESIGN FACTOR: _____

HOOK TYPE

SINGLE _____ DUPLEX _____ LOCKING _____

LOCKING HOOK _____ INSULATED HOOK _____

OTHER _____

OTHER REQUIREMENTS

CMAA SERVICE CLASS: _____

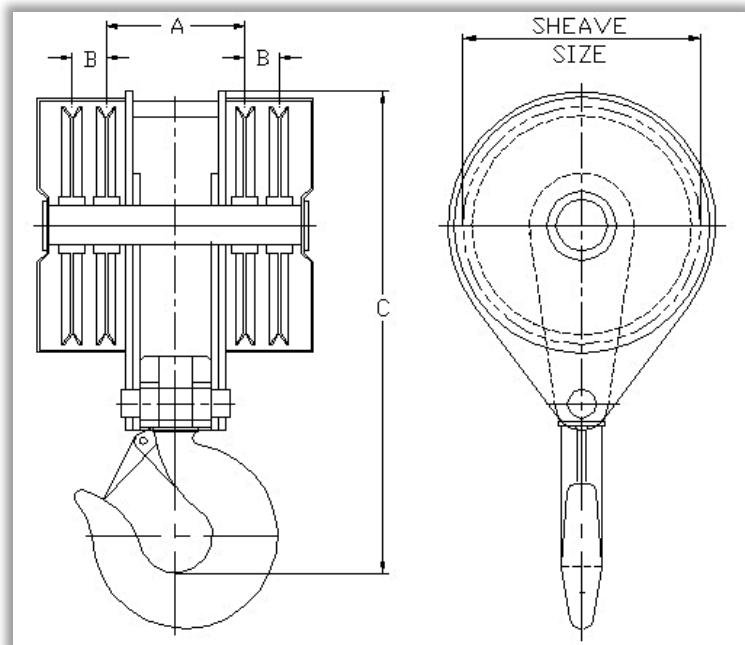

SPECIAL TESTING, THIRD PARTY INSPECTION, OVERHAUL WEIGHT, ETC:
